

iMAGs

integrated **MAG**net systems

for Electro-lifting Magnets

Load limit control

Torque control

Integrated system tester

Integrated insulation monitoring

Adjustable magnetic power

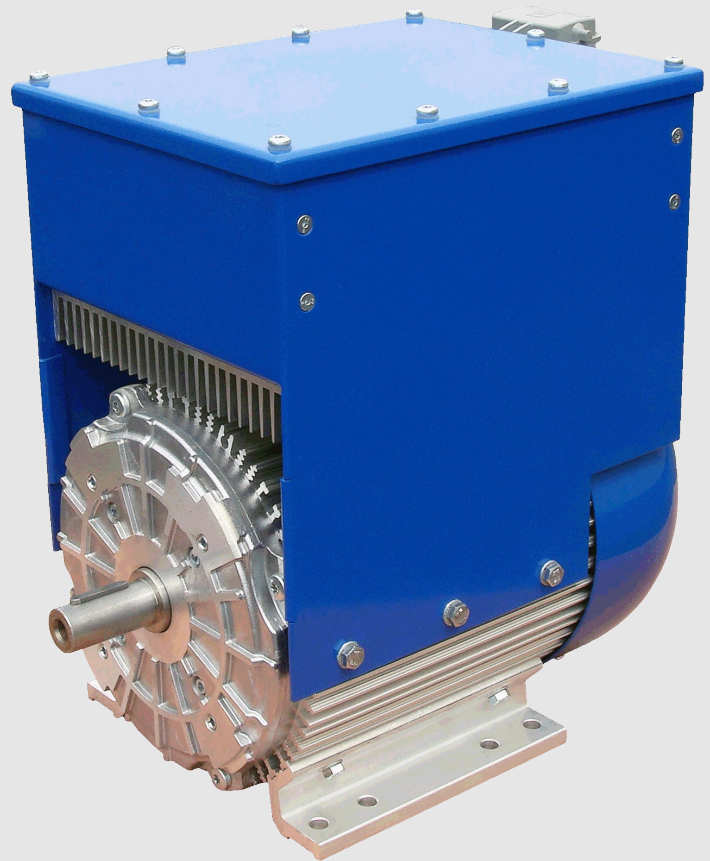

The generator system

Powerful. Innovative. Safe. Maintenance free.

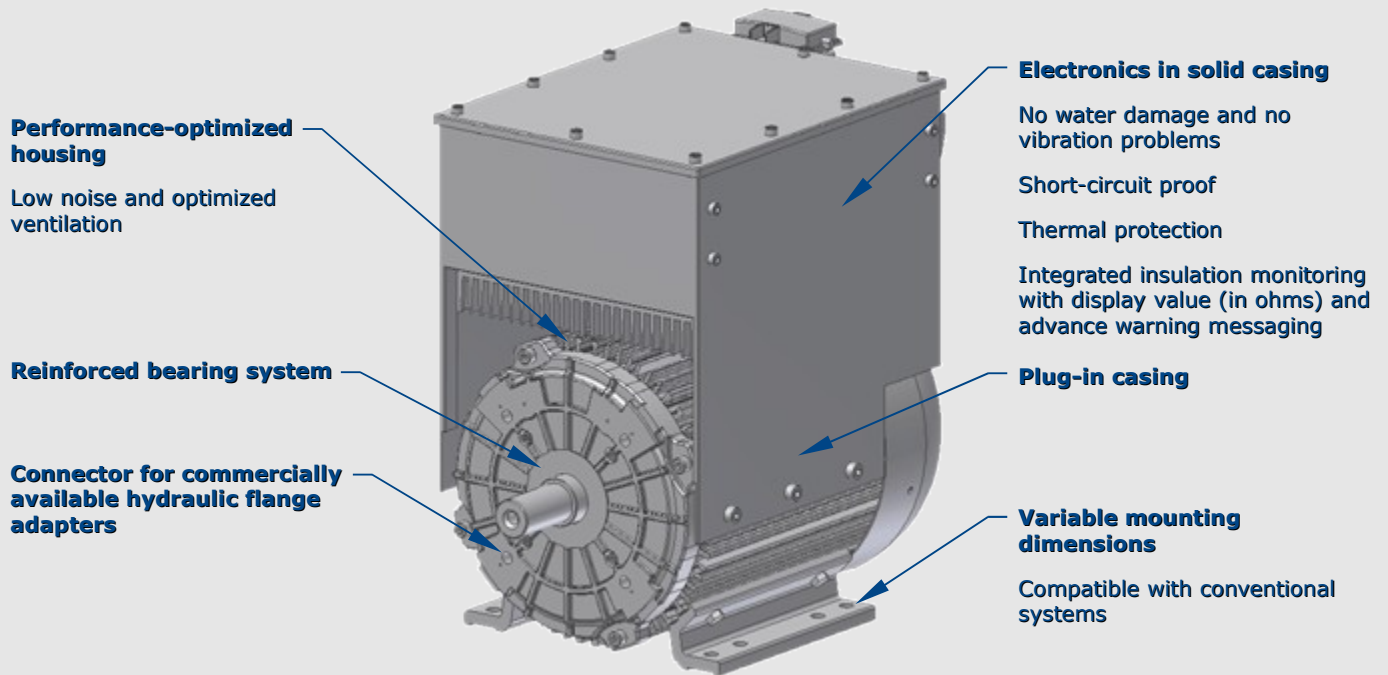

Your benefits

- **Waterproof and maintenance-free IP54 system**
- **Wide generator speed range**
- **Load limit control**
 Adjustment of the load limit can never be exceeded, regardless of the size or condition of the lifting magnet
 Hydraulic drives cannot be overloaded – no vibration
 Belt slip is eliminated
- **Torque control**
 Enhanced drive protection in the event of underspeed
- **Magnet force is fully adjustable**
- **Integrated insulation monitoring**

HMI operation (Human Machine Interface)

Easy. Intuitive. Can be personalized.

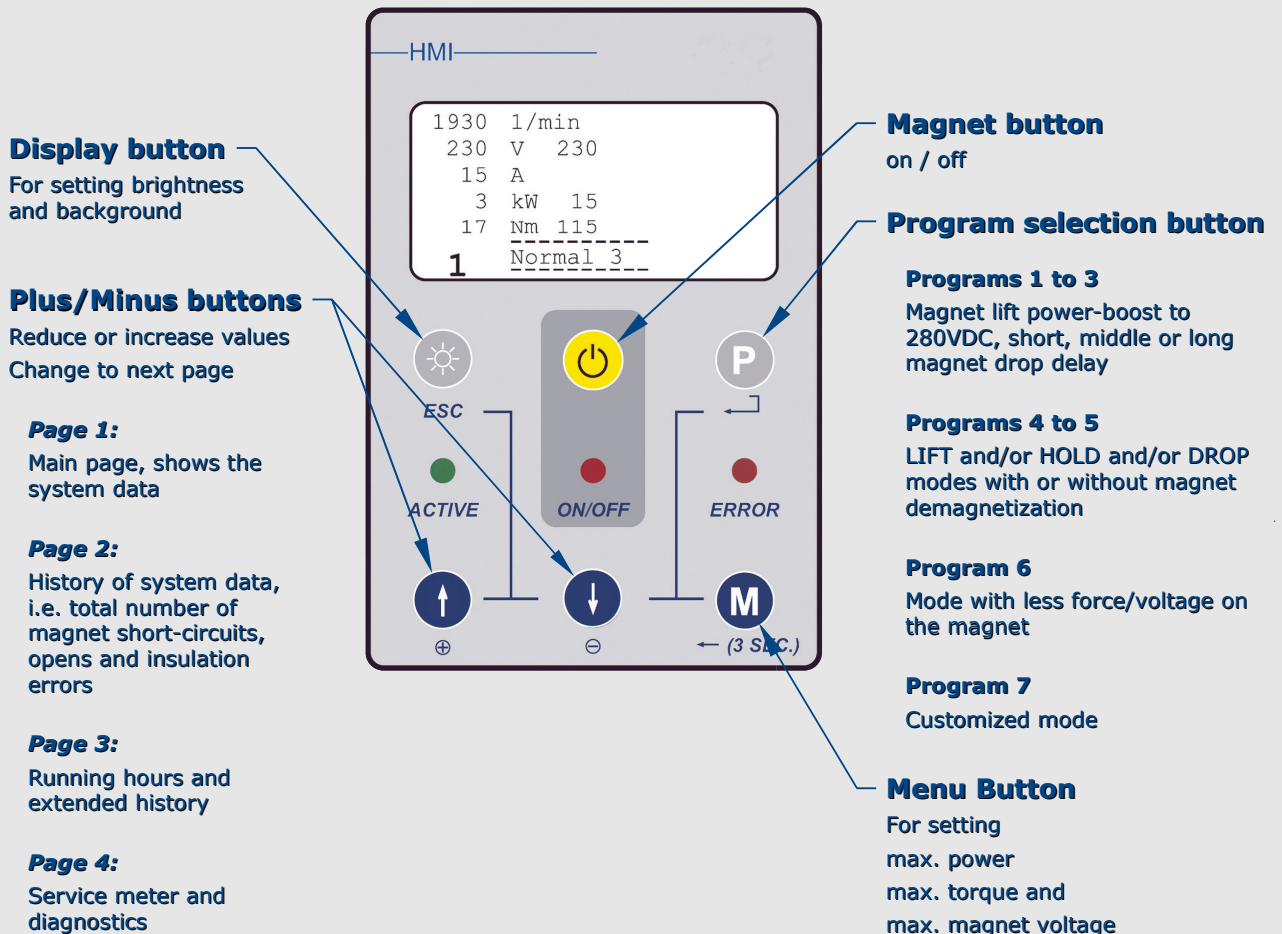
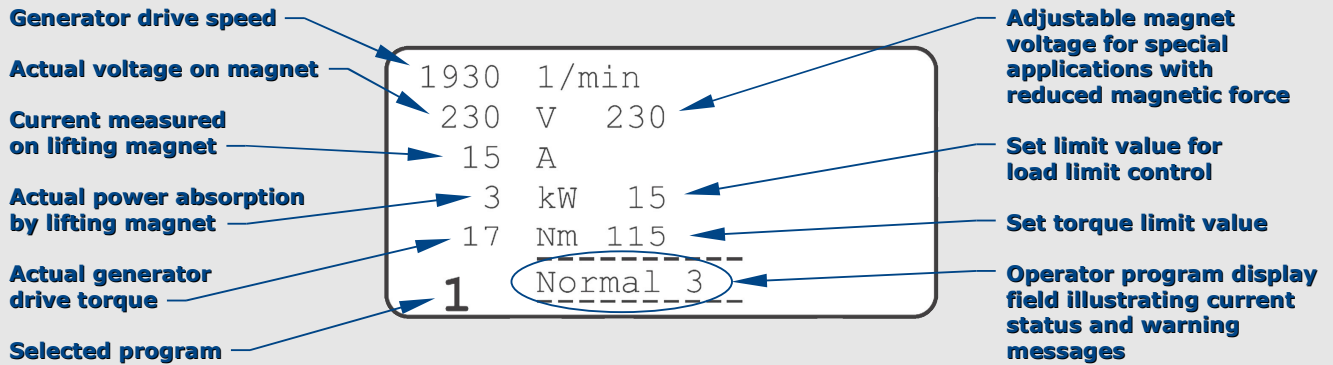

Model specifications

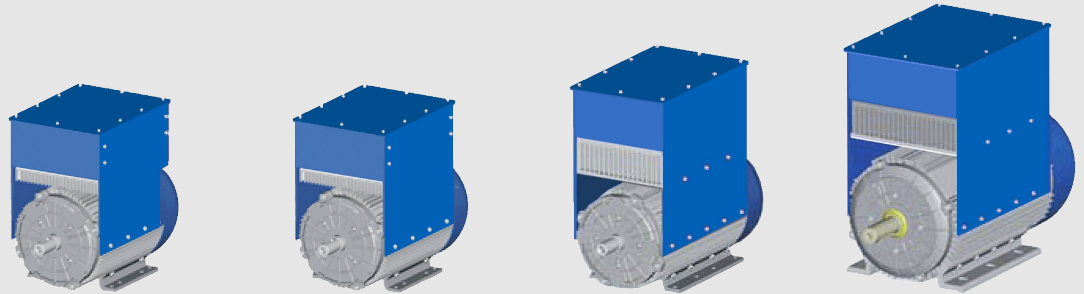

iMAGs		9		15		20		30
		2 pole	4 pole	2 pole	4 pole	2 pole	4 pole	4 pole
Nominal power 100% duty cycle - S1		9 kW	9 kW	15 kW	15 kW	20 kW	20 kW	30 kW
Nominal voltage Boost voltage		230 VDC on all models 280 VDC on all models						
Nominal current		39 A	39 A	65 A	65 A	86 A	86 A	130 A
Recommended speed Speed Range (rpm min-max)		3000 2700-4500	2000 1800-3600	3000 2700-4500	2000 1800-3600	3000 2700-4500	2000 1800-3600	1800 1500-3000
Size (mm/inch)	d	28 mm	32 mm	28 mm	32 mm	32 mm	32 mm	42 mm
	l	60 mm	60 mm	60 mm	60 mm	60 mm	60 mm	110 mm
	h	132/5.9	132/5.9	132/5.9	132/5.9	132/5.9	132/5.9	160/6.3
	x	264/10.4	264/10.4	264/10.4	264/10.4	264/10.4	264/10.4	324/12.8
	y	425/16.7	434/17.1	450/17.7	459/18.1	525/20.3	525/20.3	466/18.3
	z	427/16.8	427/16.8	427/16.8	427/16.8	505/19.9	505/19.9	565/22.2
Weight (kg/lbs)		75/165	75/165	95/210	95/210	118/260	118/260	180/397

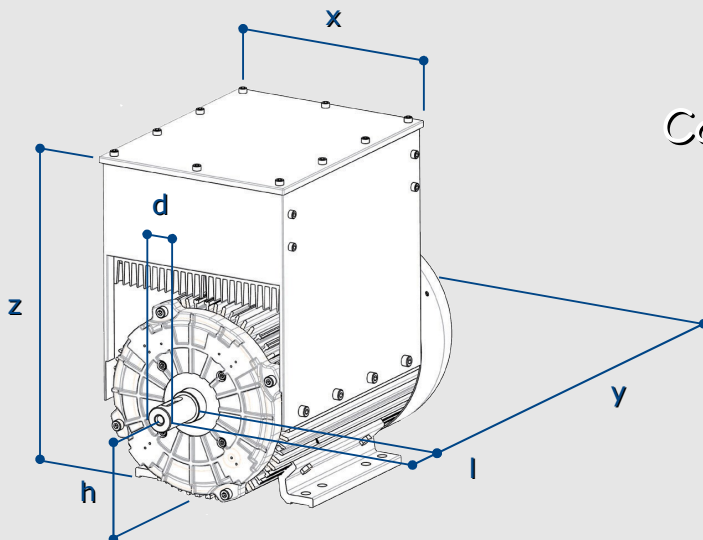

Contact:

SIEB SALES & ENGINEERING, INC.
 10001 Express Drive, Highland, IN 46322

877-924-7548 (Toll free)

www.siebsales.com

E-mail: sales@siebsales.com